



## ENGINE

Model	: ISUZU AR-4J1XASW-2
Type	: Water cooled, 4 cycle, 4 cylinders, line type direct injection, turbocharger, electronic diesel engine
Power	: 105 HP (78,5 kW) @2000 rpm / SAE J1995 (Gross) : 102 HP (76,4 kW) @2000 rpm / SAE J1349 (Net)
Max. Torque	: 375 Nm @1800 rpm (Gross) : 362 Nm @1800 rpm (Net)
Displacement	: 2999 cc
Bore and Stroke	: 95,4 mm x 104,9 mm
This engine complies with the Emission Regulations U.S. EPA Tier 4 Final, and EU Stage 4	

## UNDERCARRIAGE

Shoe	: Triple grouser 500 mm
No. Of Shoes	: 2 x 46
No. Of Lower Rollers	: 2 x 7
No. Of Upper Rollers	: 2 x 2
Track Tensioning	: Hydraulic Spring Tensioning

## CAB

- Wide cab and easy entrance
- Use of six viscomount cabin mountings that dampen the vibrations
- Cooled storage room
- Colourful, Easy to read TFT indicant monitor
- Glass holder, book and object storage pockets
- Full automatic digitally air-conditioner
- Overclass standarts on the visibility
- Pool type flor mat
- Improved operator's comfort through versatile adjustable seat
- Ergonomically redesigned cabin through relocated switch board, and re-styled travel pedals and levers
- USB connected MP3 player
- Easy to open the front sliding glass
- Front and rear sun visor
- Large storage areas
- Height adjustable joystick
- Improved seat to back angle
- The height adjustable seat armrests
- Opera Control System

## TRAVEL AND BRAKERS

Travel	: Fully hydrostatic
Travel Motors	: Axial piston type
Reduction	: 2 stage planetary gear
Travel Speed	
High Speed	: 5,7 km/h
Low Speed	: 3,4 km/h
Max. Drawbar Pull	: 11.230 kgf
Gradeability	: 35° (%70)
Parking Brake	: Hydraulic disc type, automatic warnings
Ground Pressure (500mm Shoe):	0,48 kgf/cm <sup>2</sup>

## LUBRICATION

Centralized lubrication system is provided for lubrication all difficult-to-reach parts on the components, such as boom and arm

## HYDRAULIC SYSTEM

<b>Main Pump</b>	
Type	: Double variable displacement axial piston pumps
Max. Flow	: 2 x 129 L/min
Pilot Pump	: 20 L/min
<b>Relief Valves</b>	
Cylinders	: 320 kgf/cm <sup>2</sup>
Power Boost	: 350 kgf/cm <sup>2</sup>
Travel	: 350 kgf/cm <sup>2</sup>
Swing	: 260 kgf/cm <sup>2</sup>
Pilot	: 40 kgf/cm <sup>2</sup>
<b>Cylinders</b>	
Boom	: 2 x ø110 x ø75 x 1080 mm
Arm	: 1 x ø115 x ø80 x 1225 mm
Bucket	: 1 x ø100 x ø70 x 910 mm

## OPERA CONTROL SYSTEM

- |   |   |
|---|---|
| <ul style="list-style-type: none"> <li>• Easy-to-use control panel and menus</li> <li>• Overheat prevention and protection system without interrupting the work</li> <li>• Automatical electric power-off</li> <li>• Maximum efficiency by selection of power and work modes</li> <li>• Error mode registry and warning system</li> </ul> | <ul style="list-style-type: none"> <li>• Improved fuel economy and productivity</li> <li>• Automatic idling Selection of multi-language on control panel</li> <li>• Rear-view, arm-view camera (Optional)</li> <li>• Possibility to register 26 different operating hours</li> <li>• Anti-theft system with personal code</li> <li>• Real time monitoring of operational parameters such as pressure, temperature, engine load</li> </ul> |
| <ul style="list-style-type: none"> <li>• Hidromek Smartlink</li> <li>• Automatic preheating</li> <li>• Automatical powerboost (Optional)</li> </ul>   |   |

## SWING SYSTEM

Swing Motor	: Axial piston type integrated with shock absorber valves
Reduction	: 2 stage planetary gear box.
Swing Brakes	: Hydraulic disc type, automatic warnings
Swing Speed	: 11,3 rpm

## CAPACITY

Fuel Tank	: 235 L	Engine Oil	: 16 L
Hydraulic Tank	: 115 L	Swing Reduction	: 3 L
Radiator	: 21 L	Travel Reduction	: 2,1 x 2 L
Hydraulic System	: 205 L		

## ELECTRICAL SYSTEM

Voltage	: 24V
Battery	: 2 x 12 V x 100 Ah
Alternator	: 24V / 50 A
Starting Motor	: 24V / 4 kW

## OPERATING WEIGHT

Standard machine operating weight : 16.500 kg

Operational weight, complying with the ISO 6016 standards, includes full fuel tank, hydraulic system and other liquids, 75 kg operator weight and standard equipped machine weight. Optional equipments are not included.

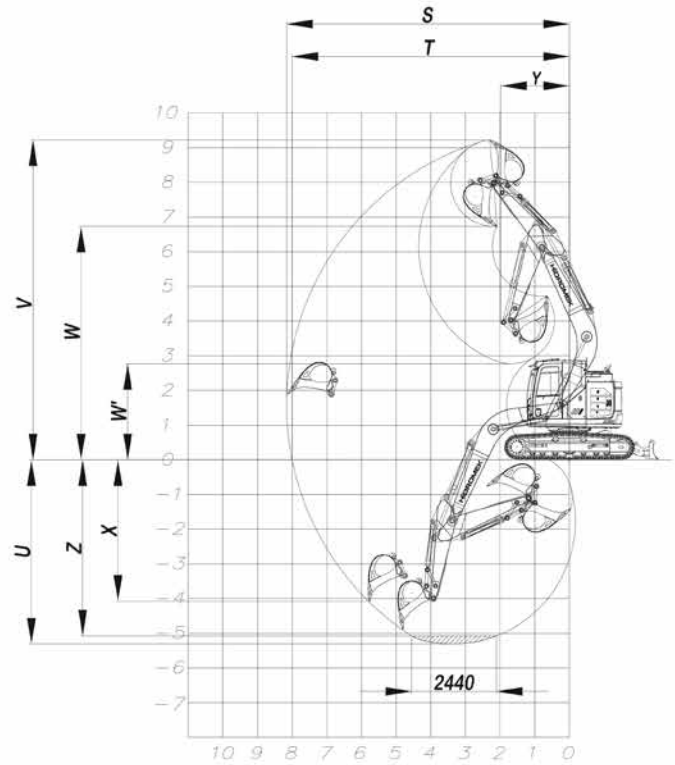
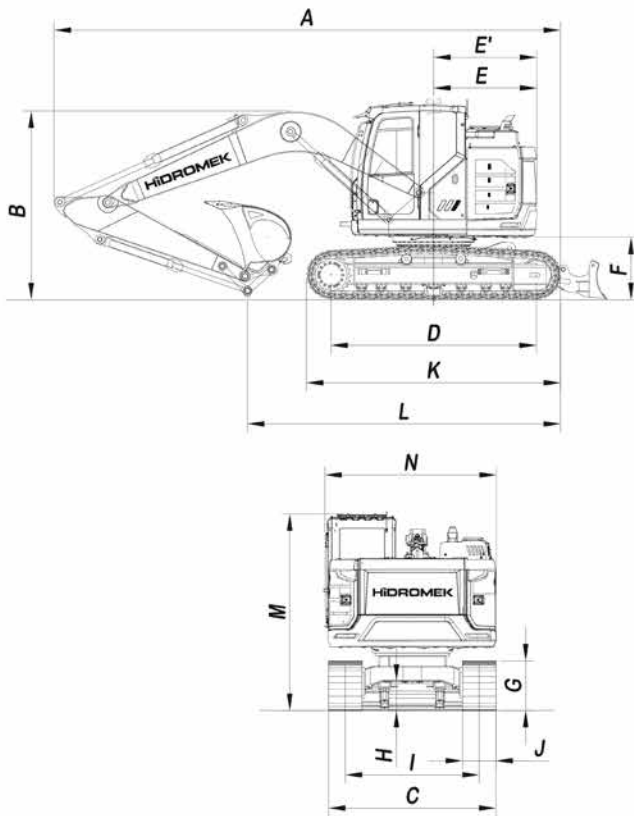

## GENERALE DIMENSIONS

Boom dimension	4600 mm			
Arm dimension	2000 mm	*2300 mm	2600 mm	2900 mm
A - Overall length	7490 mm	7510 mm	7510 mm	7500 mm
B - Overall height (to top of boom)	2740 mm	2840 mm	2960 mm	3030 mm
C - Overall width (of lower structure)	2510 mm			
D - Idler distance	3035 mm			
E - Tall swing radius	1520 mm			
F - Upperstructure ground clearance	940 mm			
G - Crawler height	800 mm			
H - Min. Ground clearance	430 mm			
I - Track gauge	1990 mm			
J - Shoe width	500 mm			
K - Overall length of crawler	3780 mm			
L - Length over ground	4800 mm	4620 mm	4460 mm	4220 mm
M - Overall height (to top of cab)	2960 mm			
N - Upperstructure width	2500 mm			

\* Standard

## WORKING DIMENSIONS

Boom dimension	4600 mm			
Arm dimension	2000 mm	*2300 mm	2600 mm	2900 mm
S - Max.digging reach	7990 mm	8270 mm	8570 mm	8860 mm
T - Max.digging reach at ground level	7830 mm	8110 mm	8420 mm	8710 mm
U - Max.digging depth	5120 mm	5420 mm	5720 mm	6020 mm
V - Max.digging height	9090 mm	9340 mm	9620 mm	9850 mm
W - Max.dumping height	6380 mm	6620 mm	6900 mm	7130 mm
W' - Min.dumping height	2930 mm	2660 mm	2380 mm	2070 mm
X - Max.vertical digging depth	4700 mm	5000 mm	5310 mm	5600 mm
Y - Min.swing radius	1870 mm	1990 mm	2120 mm	2160 mm
Z - Max. digging depth(2440mm level)	4880 mm	5200 mm	5520 mm	5840 mm

## DIGGING PERFORMANCE

Bucket Capacity (SAE)	0,6 m <sup>3</sup>	*0,6 m <sup>3</sup>	0,5 m <sup>3</sup>	0,5 m <sup>3</sup>
Bucket Digging Force (Power Boost) ISO	9100 (10000) kgf			
Arm Crowd Force (Power Boost) ISO	7500 (8200) kgf	6800 (7500) kgf	6200 (6800) kgf	5700 (6300) kgf

## HIDROMEK®

### FACTORY - HEAD OFFICE

Ahi Evran OSB Mahallesi Osmanlı Caddesi No:1 06935 Sincan / ANKARA / TURKEY  
Tel: (+90) 312 267 12 60 Fax: (+90) 312 267 12 39  
www.hidromek.com

Notice:  
Hidromek has the right to modify the specifications and design of the model indicated on this brochure without prior notice.